

DP112 / DP112MS

Stepping Motor Driver Pack

Instruction Manual
Ver. 1.05

Suruga Seiki Co., Ltd.
OST Division

INDEX

1. Introduction.....	2
1.1. Before Use.....	2
1.2. Outline of Product.....	2
2. Safety Cautions	3
3. Preparation	5
3.1. Unpacking of Product	5
3.2. Name of Parts and Main Functions	5
3.3. Main Specifications	6
3.4. Outline Dimensional Drawing.....	6
4. Installation	7
4.1. Installation Place	7
4.2. Installation of Driver Pack.....	7
5. Connection	9
5.1. Connection Examples.....	9
5.2. Connection of Power Supply.....	10
5.3. Connection of Automatic Stage Connector	11
5.4. Connection of Emergency Stop Button	12
5.5. Connection with Upper Level Controller	13
5.6. Examples of Connection with Upper Level Controller	14
5.7. Input /Output.....	19
5.7.1. Input Signal.....	19
5.7.2. Output Signal.....	21
5.7.3. Timing Chart.....	22
6. Setting	23
6.1. Opening / Closing of Chassis.....	23
6.2. Setting of Step Angle.....	24
6.3. Pulse Input Method.....	26
6.4. Smooth Drive Function.....	27
7. Checkup.....	28
8. Failure Diagnosis and Actions to be Taken	28
9. Warranty and Service	30
9.1. Warranty.....	30
9.2. Service	30
9.3. Repair Period	30

1. Introduction

Thank you for purchasing our DP112 / DP112MS stepping motor driver pack.

The instruction manual describes how to handle the product properly and the things you need to keep in mind for safety.

Please read the instruction manual carefully and use the product safely.

After reading it, keep it at hand for future reference.

- * The document is subject to change without prior notice.
- * Although the document has been created with great care, please contact our OST Division Customer Service if you find anything inconsistent, incorrect or insufficient in the contents.
- * This document may not be copied or reproduced in part or in whole without our consent.
- * Product names of other companies are listed in this document just for recommendation purpose. We have no intention to force you to use such a product or guarantee those products for you. We assume no responsibility for the performance or anything that may arise from using the products of other companies.

1.1. Before Use

The product has been designed and manufactured to be incorporated in general industrial equipment. Do not use the product for any other purpose. It is necessary to use a direct current power supply with reinforced insulation between the primary and secondary sides for the driver pack. Please note that we take no responsibility to compensate for any damages that arise from a failure to follow the warning.

1.2. Outline of Product

The product can drive our automatic stage for two axes by connecting it with an upper level controller (motion control board / PLC / sequencer).

DP112 is a driver pack for a 5 phase stepping motor (0.75A / phase) equipped with two axes of normal driver (step angles: FULL / HALF).

DP112MS is a driver pack for a 5 phase stepping motor (0.75A / phase) equipped with two axes of micro step driver (16 levels of step angles).



DP112MS has a smooth drive function, which allows automatic micro step drive inside the motor driver without changing the setting of a pulse from an upper level controller. This feature enables the unit to drive with low vibration and low noise.

In the past, to drive our automatic stage with the use of an upper level controller (motion control board / PLC / sequencer), it was necessary to process the one side of unbound cables for our automatic stage and wire them with the upper level controller and stepping motor driver. Furthermore, for the automatic stage with an EE-SX1103 sensor mounted, the use of a sensor amplifier board (K-PCBA24) was required.

This new driver pack eliminates the need of such processing and wiring.

2. Safety Cautions

The cautions shown here are intended to avoid any harms and damages to a user and surrounding people by ensuring safe, proper use of the product. Be sure to understand the cautions before using the product.

 Warning	A failure to follow the warnings may cause a death or serious injury.
 Caution	A failure to follow the cautions may cause physical injury or property damages.
Note	We have included the items in related sections that a user needs to keep in mind for safe use of the product.



Warning

General

- Do not use the product in an explosive, flammable gas, or corrosive atmosphere, or in a place exposed to water or near combustible materials. Otherwise, it may cause a fire or physical injury.
- Only a qualified person is allowed to conduct installation, connection, driving and operation, checkup, and failure diagnosis work. Otherwise, it may cause a fire or physical injury.
- To use the product on a lifting device, take appropriate measures to maintain a movable part. A motor will lose a retaining force when the power supply is off. Then, a movable part will fall off and it may cause physical injury or damage to the device.

Installation

- Install the driver pack in a chassis. Otherwise, it may cause physical injury.

Connection

- Make sure to follow the rated range of power input voltage for the driver pack. Otherwise, it may cause a fire.
- Use a direct current power supply with reinforced insulation between the primary and secondary sides for the driver pack. Otherwise, it may cause electrical shock.
- Be sure to make connections properly according to the connection diagram. Otherwise, it may cause a fire.
- Do not forcibly bend, pull, or get caught the cables including a power supply cable and a stage cable. Otherwise, it may cause a fire.

Driving

- In case of power outage, cut off the power supply for the driver pack. Otherwise, a motor will abruptly start again when the electricity is back and it may cause physical injury or damage to the device.
- Do not turn the AWOFF (output current off) input ON while a motor is running. The motor will stop and lose a retaining force. It may cause physical injury or damage to the device.

Repair, Disassembly, Remodeling

- Do not disassemble or remodel the driver pack. Otherwise, it may cause physical injury. To check the inside or repair the product, please contact our OST Division Customer Service.



Caution

General

- Do not use the driver pack outside its specification values. Otherwise, it may cause physical injury or damage to the device.
- Do not put a finger or any object in the opening of the driver pack. Otherwise, it may cause a fire or physical injury.
- Do not forcibly bend or pull the cables including a power supply cable and a stage cable. Otherwise, it may apply stress to the driver pack and cause damage.

Conveyance

- Do not carry the unit with holding the cables including a power supply cable and a stage cable. Otherwise, it may cause a fire, physical injury or damage to the device.

Installation

- Do not place any combustible materials around the driver pack. Otherwise, it may cause a fire or burn injury.
- Do not place any obstacles to proper ventilation around the driver pack. Otherwise, it may cause damage to the device.

Operation

- Use the driver pack together with our automatic stage. Otherwise, it may cause a fire.
- In case of a failure of the device or abnormal operation, install an emergency stop device or circuit externally so that the device will operate to the safe side as a whole. Otherwise, it may cause physical injury.
- When supplying power to the driver pack, be sure to turn all input signals of the driver pack OFF in advance. Otherwise, the motor will start working and it may cause physical injury or damage to the device.
- When moving the motor output axis directly by hand (e.g. manual position alignment), be sure to confirm the AWOFF (output current off) input of the driver pack is ON in advance. Otherwise, it may cause physical injury.
- When something abnormal happens, stop the unit and cut off the power supply to the driver pack at once. Otherwise, it may cause a fire or physical injury.

Disposal

- Dispose of the driver pack as industrial waste after disassembling it as much as possible.

3. Preparation

The section describes what you need to check before using the product, the names of each part, their functions and main specifications.

3.1. Unpacking of Product

After unpacking the product, make sure everything is in the package as follows.

If there are missing parts or something damaged, please contact our OST Division Customer Service.

- DP112 or DP112MS (main body): 1 unit
- Warranty: 1 copy
- Connector and connector cover: 1 set (in a bag)

* Items included as 1 set (in the bag)

Connector (soldering type)	10136-3000PE (x 1) made by 3M
Connector Cover	10336-52F0-008 (x 1) made by 3M

Note:

- When taking out the driver pack, be careful not to touch it with electrically charged hands. Electrostatic discharge may damage the product.
- The instruction manual does not come with the product for a resource saving purpose. If you need one, please ask our OST Division Sales Group. You can also download the manual from our web site:
<http://www.suruga-ost.com/manuals>

3.2. Name of Parts and Main Functions

The table below shows the names of each part of the driver pack and their main functions.

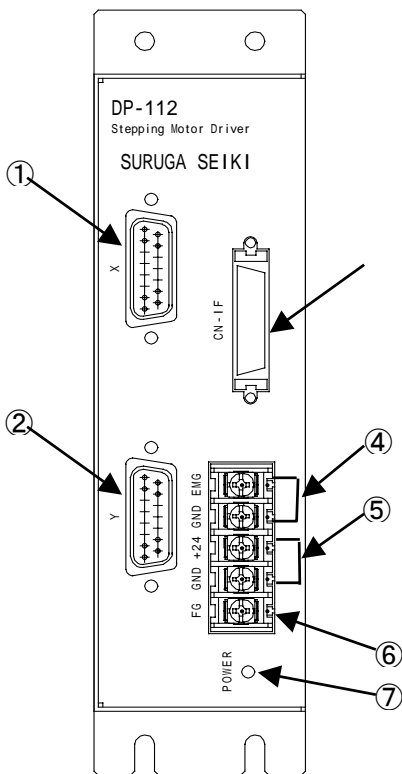

No.	Name	Description
(1)	Connector for stage (X-axis)	A connector to connect the product with an automatic stage (X-axis).
(2)	Connector for stage (Y-axis)	A connector to connect the product with an automatic stage (Y-axis).
(3)	Connector for upper level controller	A connector to connect the product with an upper level controller.
(4)	Emergency stop button connection terminal	A terminal for connecting the product with an emergency stop button. This will be enabled by connecting the emergency stop signal of an upper level controller with (3). Note: • Emergency stop functions will be different depending on the specifications of an upper level controller. Be sure to understand the specifications well before connecting them. • The terminal is not for cutting off the power supply to the driver pack.
(5)	DC power supply input terminal	A terminal for DC power supply input. It will supply the power of DC24V±10% (3A or more).
(6)	FG terminal	An earth terminal.
(7)	Power lamp	While the power is supplied, the LED will be lit up in red.

Note: Be sure to connect the power supply for the driver pack with correct polarity. Wrong polarity may cause a fire or damage to the device.

3.3. Main Specifications

	DP112	DP112MS
Power Input Voltage	DC24V±10%; 3A or more	
Rated Current	0.75A / phase	
Driver Type	Normal (FULL / HALF)	Micro Step (16 levels)
Input Signal	Photo coupler input Signal voltage: Photo coupler ON : +4.5V - +5V Photo coupler OFF : 0V - +0.5V CW, CCW, AWOFF, F/H, CDINH: DC5V, 20mA or less, Input resistance 220Ω	
Pulse Input	2 pulse method (normal / reverse rotation pulse)	Can be chosen between 1 pulse method (pulse / direction) and 2 pulse method (normal / reverse rotation pulse)
Output Signal	Open collector output (+5V - +24V, 30 mA or less) CWLS, CCWLS, NORG, ORG: Output OFF when a sensor detects (for normally close sensor logic) Output ON when a sensor detects (for normally open sensor logic)	
	TIMING signal: When the excitation sequence is at step 0, output ON For FULL: Output once in 10 pulses For HALF: Output once in 20 pulses	TIMING signal: When the excitation sequence is at step 0, output ON For 1 division: Output once in 10 pulses For 10 divisions: Output once in 100 pulses
Output Voltage / Current	+5V power output: DC5V±5% / 200 mA or less	
	+24V power output: DC24V±10% / 300 mA or less	
Cooling Method	Natural air cooling	
Mass	ca. 780 g	
Operational Temperature Range	0 C - +40 °C (No freeze)	

3.4. Outline Dimensional Drawing

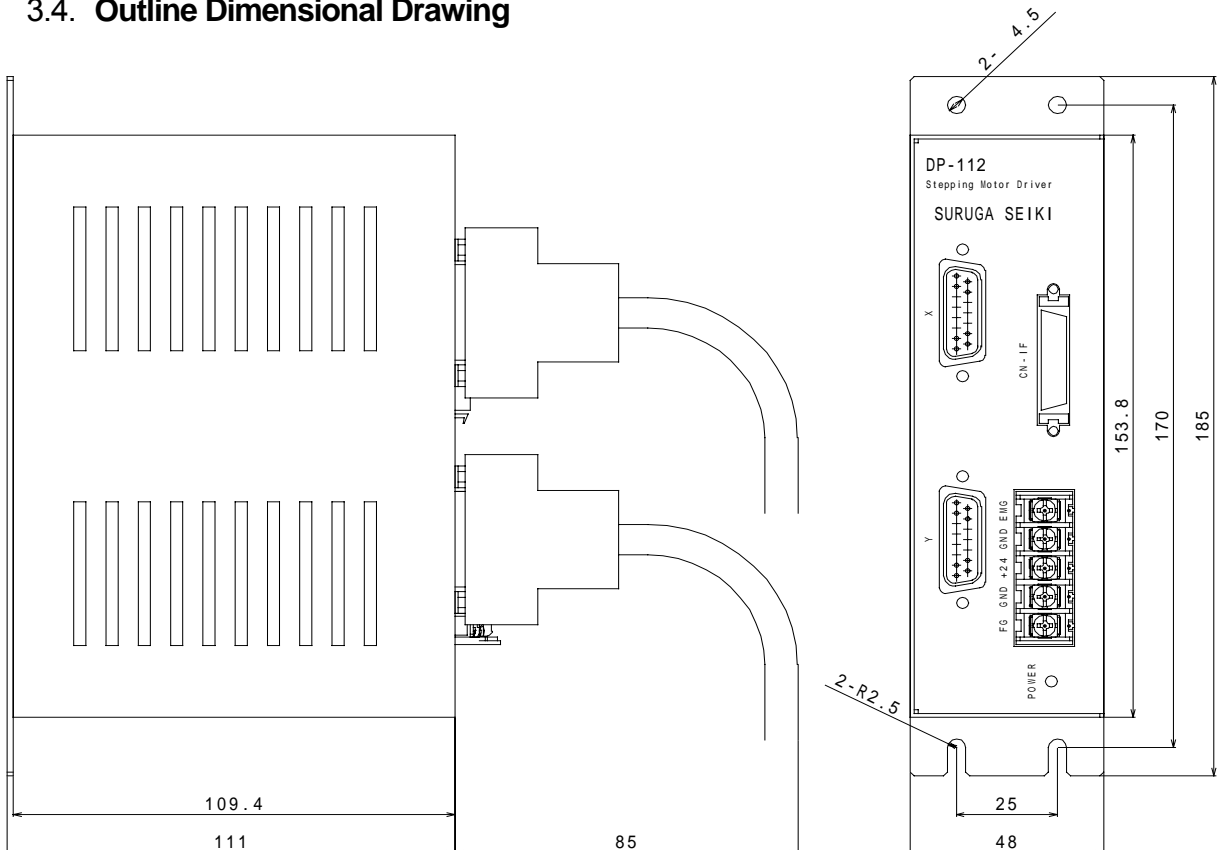

4. Installation

The section describes where and how to install the driver pack.

4.1. Installation Place

The driver pack has been designed and manufactured to be incorporated in equipment. Install the product in a place that meets the following conditions with proper ventilation and easy access for checkup:

- In a chassis installed indoors (a ventilation port is to be provided)
- Operational ambient temperature: 0 °C - +40 °C (No freeze)
- Operational ambient humidity: 85% or less (No condensation)
- Free from explosive atmosphere and where there is no toxic gases (e.g. sulfidizing gas) and liquids
- Away from direct sunlight
- Where there is less dust or iron powders
- In a place not exposed to water (e.g. weather and water drop), oil (oil drop) and other liquids
- Where there is less salt content
- Free from any continuous vibration or excessive impact
- Where there is less electromagnetic noise (e.g. welder and power equipment)
- Where there are no radioactive substances or magnetic field. Not in vacuum.

4.2. Installation of Driver Pack

Using the 4 mounting holes in the driver pack, fix the product with 4 screws (M4: not included in our package).

Install the driver pack at least 20 mm horizontally away and at least 30 mm vertically away from the chassis and other equipment.

If you install more than one driver pack side by side, be sure to install them at least 20 mm horizontally away and at least 30 mm vertically away from each other.

Note:

- **Do not place such equipment around the driver pack that generates a large amount of heat or large noise.**
- **If the ambient temperature of the driver pack exceeds 40 °C, review the ventilation conditions.**
- **Do not direct downward or block the ventilation port of the driver pack.**

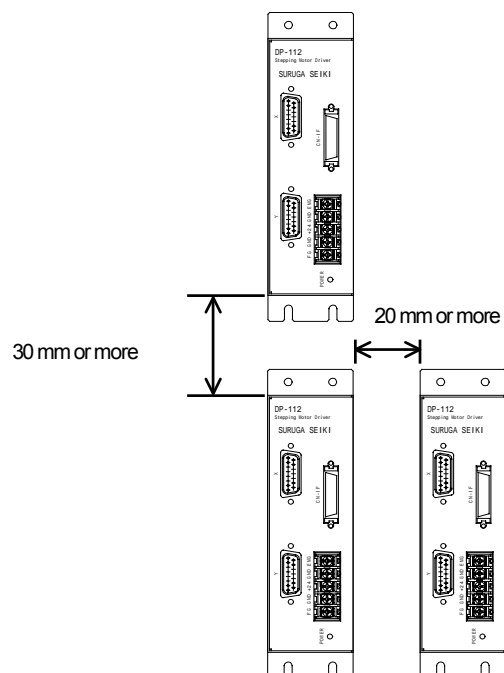

~ Attachment to DIN Rail ~

When using a DIN rail, choose the one with a rail width of 35 mm or more.

1. Remove the 3 screws that fix the mounting plate at the back of the driver pack.

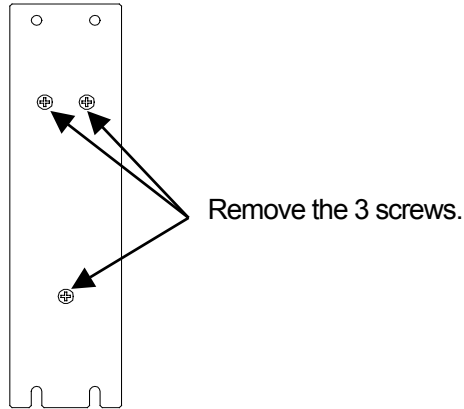

2. Attach the DIN rail attachment plate (product name: PADP01 (option)) at the back of the driver pack at the three points with screws.

The screws come with the DIN rail attachment plate.

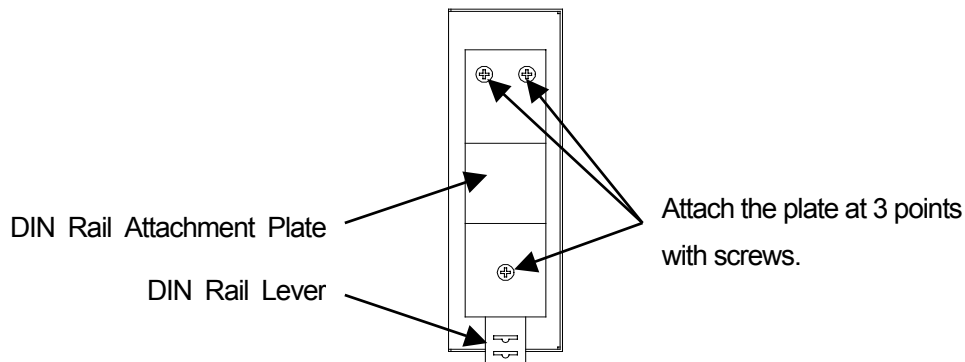

3. Pull the DIN lever down, hook the claw at the upper side of the DIN rail attachment plate on the DIN rail, and press it until the DIN lever is locked.

Note:

- Do not use the mounting holes (M3: 3 points) at the back of the driver pack for any other purpose than fixing the DIN rail attachment plate.
- To fix the DIN rail attachment plate, be sure to use the screws that come with the product. Using a screw that enters by more than 3 mm from the surface of the driver pack may damage the driver pack.
- Use an end plate (not included in the package) to fix the driver pack.

~ Removal from DIN Rail ~

Pull down and lock the DIN lever using a slotted screwdriver or other tools. Lift the driver pack up by holding the bottom and remove it.

Note:

When pulling down and locking the DIN lever, pull it with the force of about 10 - 20 N. Too strong force may damage the DIN lever.

5. Connection

The section describes how to connect the driver pack with an automatic stage, power supply, and an upper level controller, examples of connection, and input and output signals.

5.1. Connection Examples

~ Overall View ~

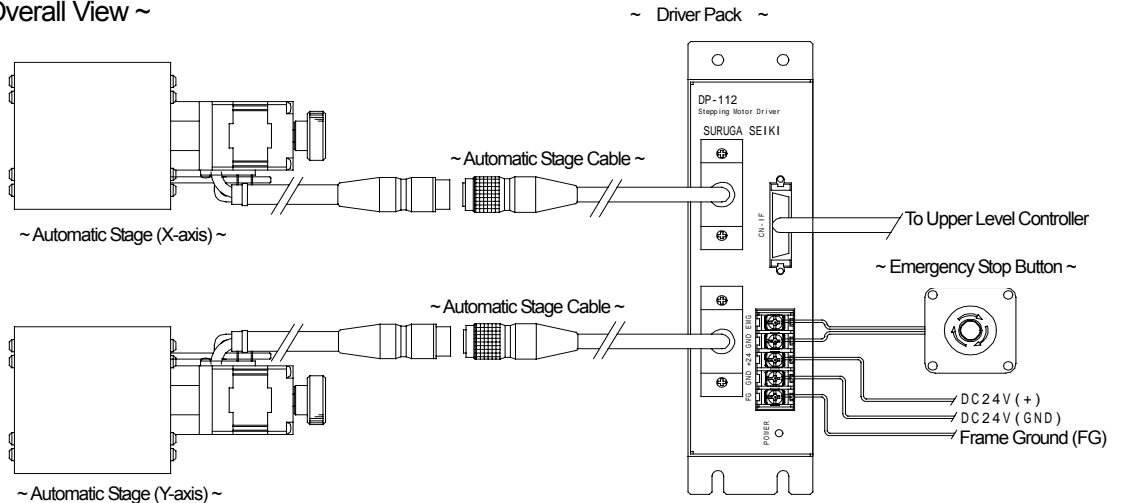

~ CN-IF and Emergency Stop Button ~

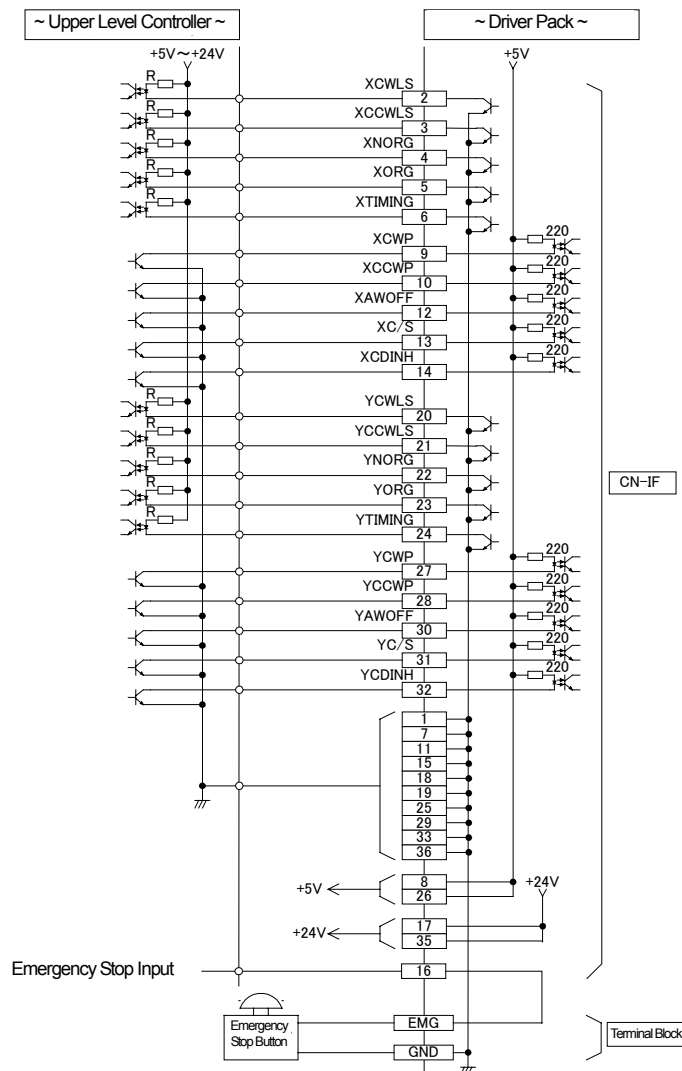

5.2. Connection of Power Supply

All the diagrams shown for illustration purposes are the image with the cover of a terminal block removed.

Warning

- After successfully connected, be sure to attach a terminal cover (included in the package). Otherwise, it may cause electrical shock or a fire.

Note:

- Prepare a power supply that can sufficiently supply the power input current for the driver pack.
If a current capacity is insufficient, thrust (torque) will decrease and abnormal rotation of a motor may occur.
- Do not place a power supply cable for the driver pack in the same wiring as other power supply lines or a motor cable.

Use such power supply that can supply the following current capacity:

Input power supply voltage — DC24V \pm 10%

Power current capacity — 3A or more

Connect a power supply cable with the power supply connection terminal in the driver.

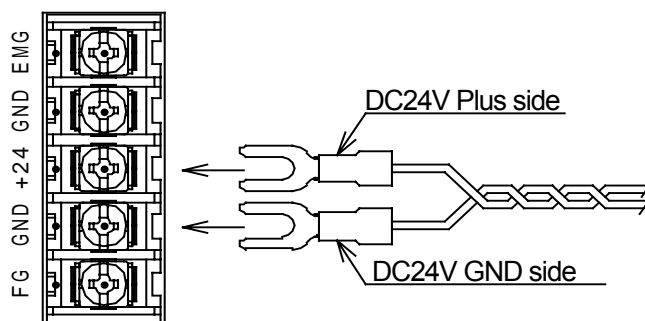

* Terminal screw size of power supply connection terminal and cable size:

Terminal screw size: M3

Tightening torque: 0.8 - 1.0N·m (8 - 10 kgfcm)

Cable size: AWG22 or less

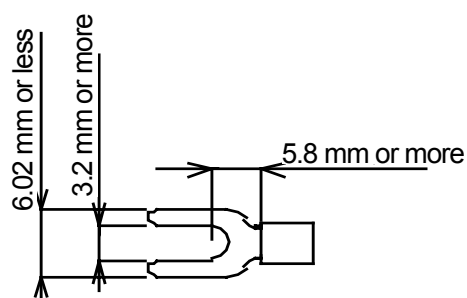

5.3. Connection of Automatic Stage Connector

Use an automatic stage connection cable as follows:

- 2 m cable: DP112-1-2E / DP112-2-2E

If you want a robot cable design or want to designate the length of a cable, please contact our OST Division Customer Service.

[Connector to be used]

Connector model No.: DA-15SF-N

(made by JAE:D-Sub 15pin female)

Conforming connector: DA-15PF-N

(made by JAE:D-Sub 15pin male)

Conforming connector: DA-C8-J10-F1-1 (made by JAE)

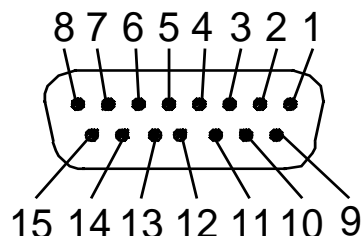

[Pin-out]

Pin No.	Signal	Input / Output	Terminal Function
1	MOTOR	Output	Motor lead (Blue)
2		Output	Motor lead (Red)
3		Output	Motor lead (Orange)
4		Output	Motor lead (Green)
5		Output	Motor lead (Black)
6	GND	Output	Sensor power supply ground
7	ORG	Input	Origin sensor input
8	+5V	Output	Sensor power supply (DC+5V)
9	+24V	Output	Electromagnetic brake power supply (DC+24V)
10	GND	Output	Electromagnetic brake power supply ground
11	CWLS	Input	CW limit sensor input
12	CCWLS	Input	CCW limit sensor input
13	NC		No connection
14	NORG	Input	Near origin sensor input
15	NC		No connection

* The pin-out is the same for both an X-axis connector and a Y-axis connector.

5.4. Connection of Emergency Stop Button

By connecting the emergency stop signal available in an upper level controller with the upper level controller connector in the driver pack, the product can be controlled through an emergency stop button connection terminal.

The internal circuit of the driver pack is as follows:

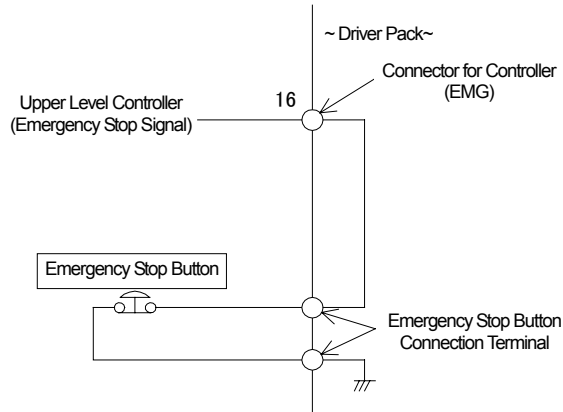

Note:

The specifications for emergency stop are different depending on the model of an upper level controller to be connected. Therefore, when connecting an emergency stop button, be sure to check the specifications of the upper level controller to be connected.

Connect a cable for an emergency stop button with the emergency stop button connection terminal.

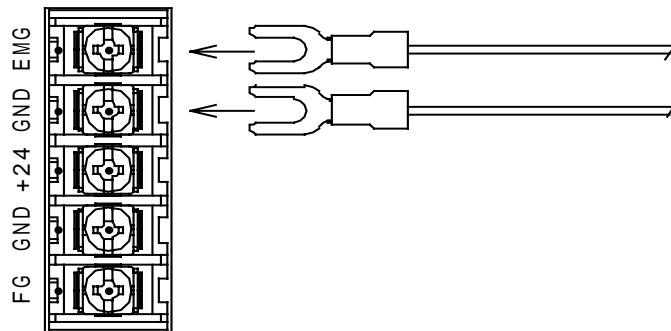

* Terminal screw size of power supply connection terminal and cable size:

Terminal screw size: M3

Tightening torque: 0.8 -1.0 N·m (8 - 10 kgfcm)

Cable size: AWG26 or less

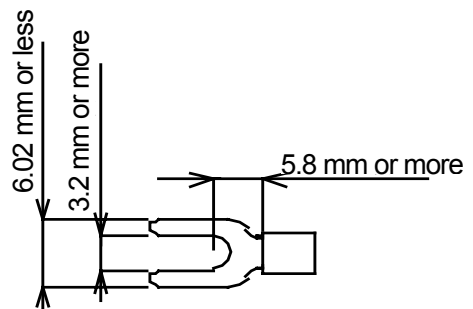

5.5. Connection with Upper Level Controller

Using the connector that comes with the driver pack, connect the product with an upper level controller.

Note:

- Insert the connector all the way in.
Improper insert of a connector may cause poor operation or damage to the motor and/or driver.
- When restoring the power supply or mating and unmating the connector for a motor cable, wait for at least five seconds after cutting off the power supply.
- Place the cables to be connected at least 100 mm away from induction load including an electromagnetic relay and also place them not in parallel with a power supply cable or a motor cable.
- It is recommended to use a shielded wire for the selected cable to minimize the influence of noise.

[Connector to be used]

Connector model No.: 10236-55F3VC (made by 3M)

Conforming connector: 10136-3000VE

(made by 3M; accessory)

Conforming connector cover: 10336-52F0-008

(made by 3M; accessory)

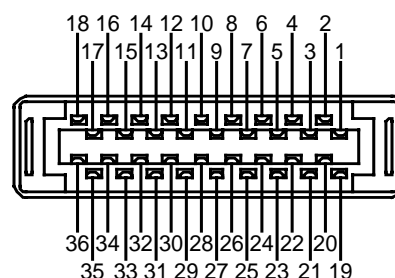

~ Viewed from Soldering Side ~

[Pin-out]

No.	Signal	Description	No.	Signal	Description
1	GND	Ground	19	GND	Ground
2	XCWLS	X-axis CW limit sensor output	20	YCWLS	Y-axis CW limit sensor output
3	XCCWLS	X-axis CCW limit sensor output	21	YCCWLS	Y-axis CCW limit sensor output
4	XNORG	X-axis near origin sensor output	22	YNORG	Y-axis near origin sensor output
5	XORG	X-axis origin sensor output	23	YORG	Y-axis origin sensor output
6	XTIMING	X-axis excitation timing output	24	YTIMING	Y-axis excitation timing output
7	GND	Ground	25	GND	Ground
8	+5V	+5V output	26	+5V	+5V output
9	XCWP	X-axis CW pulse input	27	YCWP	Y-axis CW pulse input
10	XCCWP	X-axis CCW pulse input	28	YCCWP	Y-axis CCW pulse input
11	GND	Ground	29	GND	Ground
12	XAWOFF	X-axis excitation OFF signal input	30	YAWOFF	Y-axis excitation OFF signal input
13	XC/S	X-axis step angle switching signal input	31	YC/S	Y-axis step angle switching signal input
14	XCDINH	X-axis current reduction disabling signal input	32	YCDINH	Y-axis current reduction disabling signal input
15	GND	Ground	33	GND	Ground
16	EMG	Emergency stop output	34	N.C.	No connection
17	+24V	+24V output	35	+24V	+24V output
18	GND	Ground	36	GND	Ground

Note:

- Set the voltage for an input signal (CW, CCW, AWOFF, F/H, and CDINH) at DC5V.
- Set the voltage and current for an output signal (TIMING, CWLS, CCWLS, NORG, and ORG) at not less than DC5V and not more than DC24V and 30mA or less.

5.6. Examples of Connection with Upper Level Controller

The section shows examples of connection with the upper level controllers supplied by various companies.

In the case of MC8043P made by NOVA Electronics

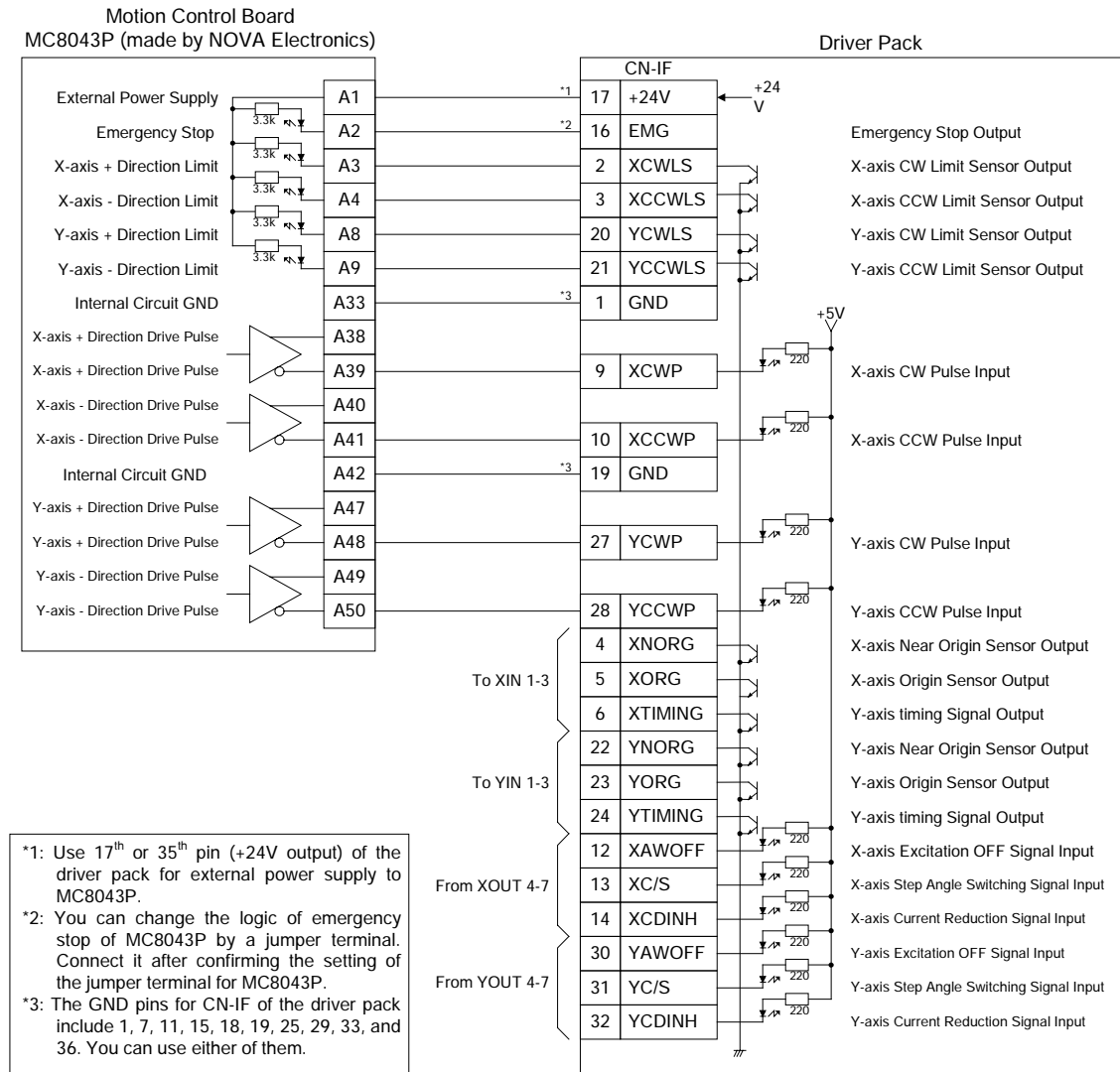

In the case of KV-1000 made by Keyence

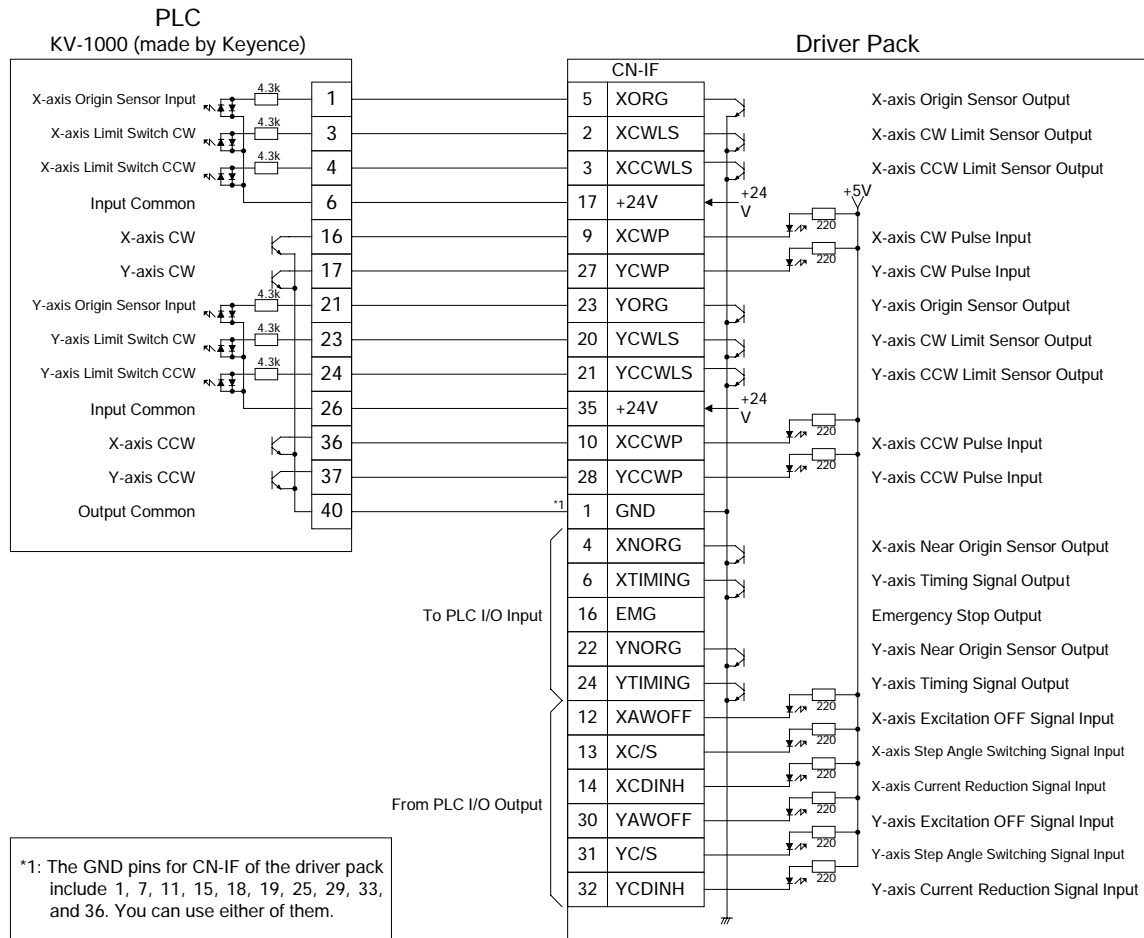

In the case of CS1W-NC213 made by Omron

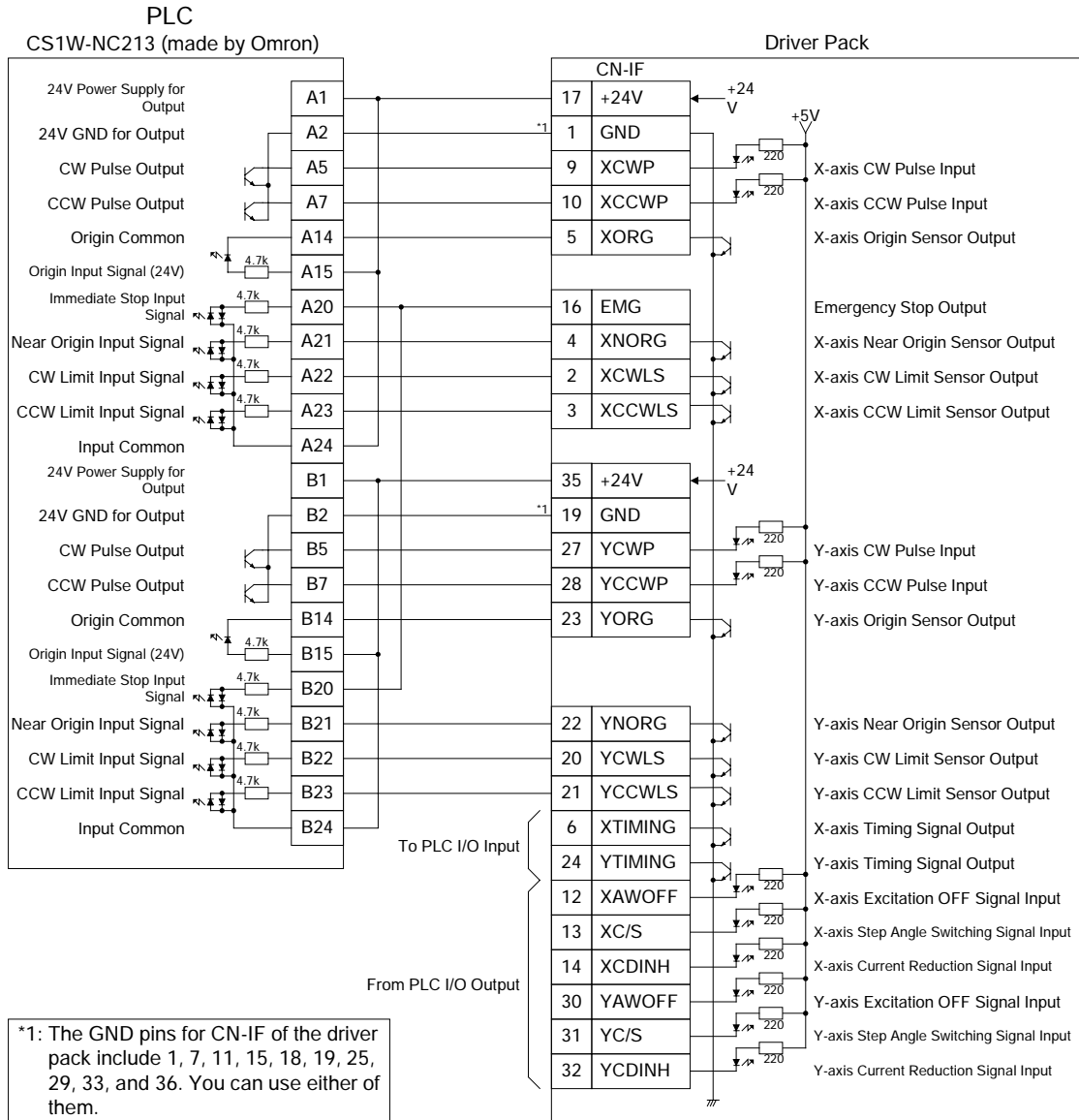

In the case of CS1W-NC233 made by Omron

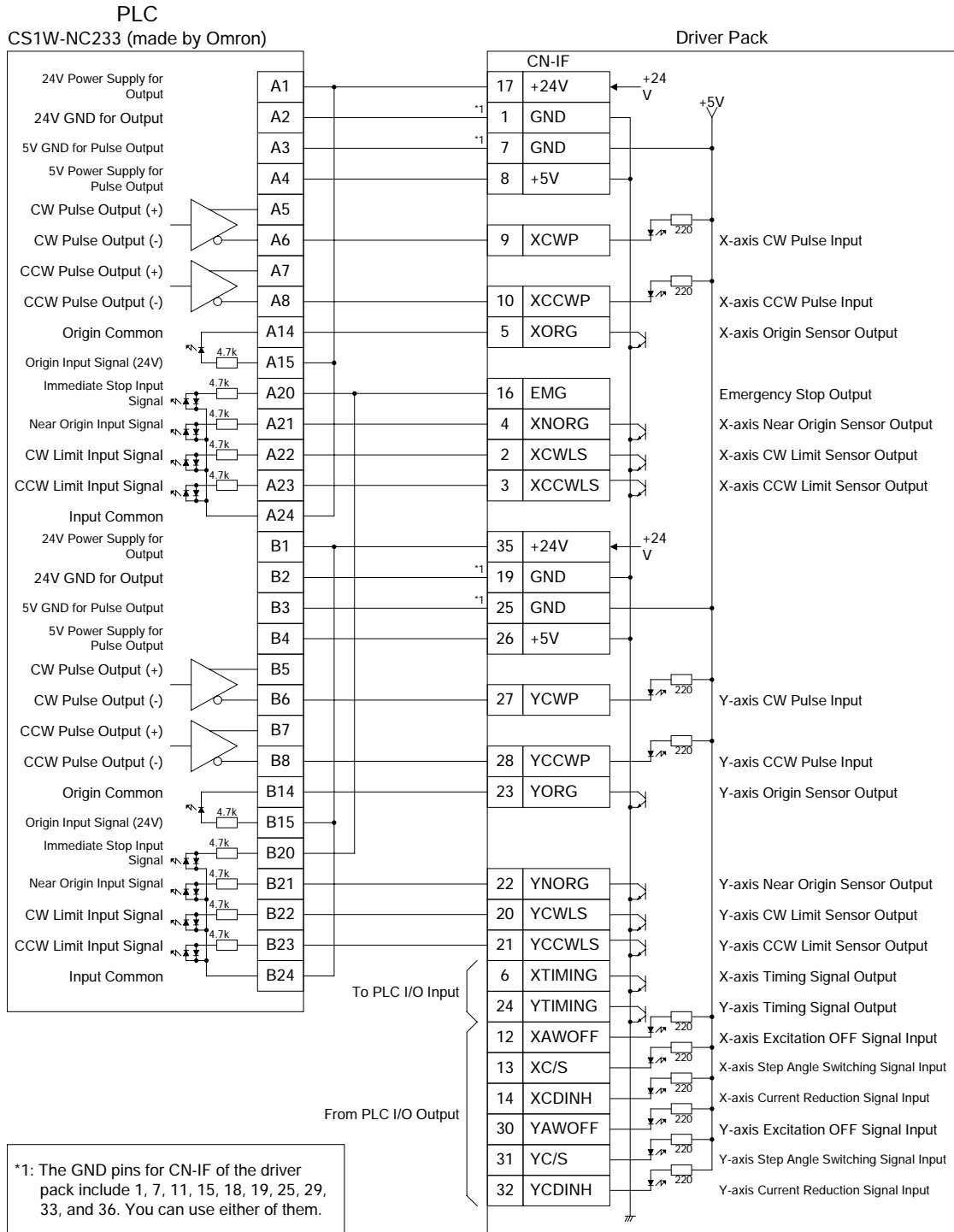

5.7. Input /Output

5.7.1. Input Signal

The section describes ON of an internal photo coupler as energized and OFF as non-energized for the input area of photo coupler input.

5.7.1.1. Drive Pulse Input (CW/CCW)

Connect the X-axis CW pulse of an upper level controller with XCWP (Pin No. 9), the Y-axis CW pulse with YCWP (Pin No. 27), the X-axis CCW pulse with XCCWP (Pin No. 10), and the Y-axis CCW pulse with YCCWP (Pin No. 28).

~ For a controller of open collector ~

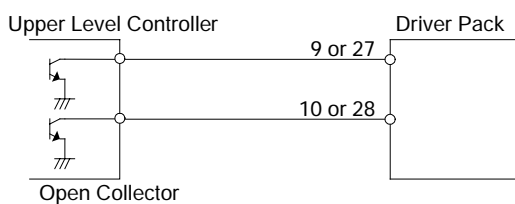

~ For a controller of line driver ~

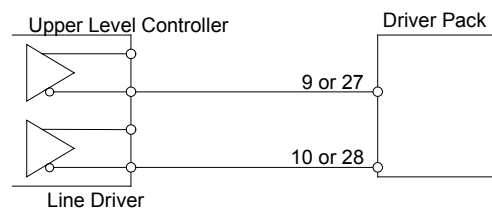

Note: Connect ground of the upper level controller to be connected with that of the driver pack. Otherwise, it may change the ground level and a pulse input may not be possible.

1. By switching the CW pulse input from ON to OFF, the motor will rotate by 1 step in the CW direction.
2. By switching the CCW pulse input from ON to OFF, the motor will rotate by 1 step in the CCW direction.

For a pulse signal, input a pulse waveform with sharp rising and falling edges as shown below.

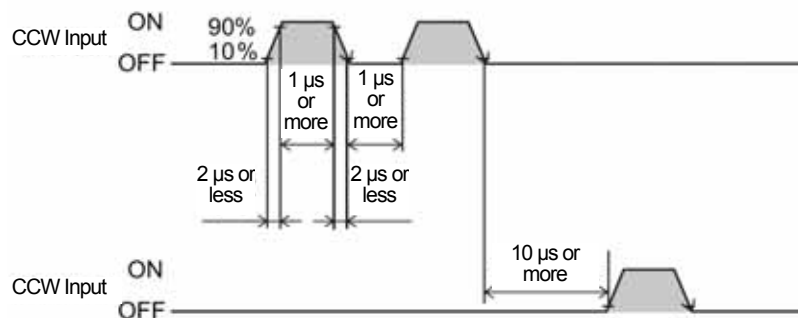

Note:

- The minimum interval time when switching the rotation direction will vary depending on the size of a motor, operation speed and load inertia moment. Do not make it shorter than necessary.
- While a motor is at rest, make sure to turn the pulse signal “photo coupler OFF”. If a photo coupler is ON, it will not go down to the set current for at rest.
- Do not input a CW input and CCW input at the same time.
If a pulse is input when either of them is ON, a motor cannot operate properly.

5.7.1.2. AWOFF (Excitation off) Input

Use the AWOFF (excitation off) input to adjust the position by rotating a motor from the output axis side.

Warning

- Do not turn the AWOFF (excitation off) input ON while a motor is running. The motor will stop and lose a retaining force. It may cause physical injury or damage to the device.

Caution

- When moving the motor output axis directly by hand (e.g. manual position alignment), be sure to confirm the AWOFF (excitation off) input of the driver is ON in advance. Otherwise, it may cause physical injury.

Once the AWOFF input is ON, current to the motor will be off.

Then the motor will lose a retaining force, which allows you to adjust the position of the motor output axis.

If the AWOFF input is OFF, current to the motor will be on. The motor will regain a retaining force.

Note:

- When the AWOFF input is not in use, turn it OFF or do not connect it.

5.7.1.3. C/S (Step Angle Switching) Input

- As for DP112, it switches the step angles of the motor between FULL and HALF steps. If the step angle of the motor is 0.72° ,
 - it will rotate at a 0.36° step (HALF) when the C/S input is ON.
 - it will rotate at 0.72° step (FULL) when the C/S input is OFF.
- As for DP112MS, it chooses the step angles between those specified with two switches for step angle setting (DATA1 and DATA2).

For example, if you set DATA1 at $[0:0.72^\circ]$ and DATA2 at $[6:0.072^\circ]$, you can switch the operation between 0.72° step and 0.072° step with this signal.

For more details on how to set the step angle setting switches, please see 6.2 Step Angle.

 1. Turning the C/S input ON will switch to the setting of the step angle setting switch DATA2.
 2. Turning the C/S input OFF will switch to the setting of the step angle setting switch DATA1.

Note:

- When switching the step angles with the C/S (step angle switching) input, make sure to turn the TIMING output ON and do it while a motor is at rest.
If you switch the C/S (step angle switching) input under any other condition, step switching will not be possible and the TIMING output may not be ON.

5.7.1.4. CDINH (Current Reduction Disabling) Input

It is for inputting a current reduction disabling signal. (The functions are a little different between DP112 and DP112MS.)

<DP112>

Turning the CDINH input ON will disable the automatic current reduction function while a motor is at rest. In this state, you can adjust the current for motor operation. (For more details, please refer to the instruction manual for the built-in driver SD5107P2-A3.)

* While a motor is running, make sure to turn it OFF. If it is ON, a motor will not rotate.

<DP112MS>

Turning the CDINH input ON will disable the automatic current reduction function while a motor is at rest.

Turning the CDINH input OFF will enable the automatic current reduction function while a motor is at rest, which suppress the heat generation in the motor and driver by automatically reducing the output current to the motor within about 0.1 second after a pulse stops.

5.7.2. Output Signal

The output method is open collector output (30 mA or less).

5.7.2.1. TIMING (Excitation Timing) Output

The driver pack will turn the TIMING output ON when the excitation status of a motor (the combination of phase where current flows) is at the excitation origin (step [0]). The excitation status of a motor will be reset to the excitation origin when the power is applied to the driver pack.

The TIMING output will synchronize with a pulse input and will be ON every time the motor rotates by 7.2°. When you input a multiple of the number of pulses needed for a motor to rotate by 7.2° as a pulse signal, you can check that the driver is operating properly by monitoring the TIMING output.

Additionally, if you configure an AND circuit with a mechanical origin sensor and the TIMING output to detect the mechanical origin of a machine device, you can minimize the variations in a motor stopping position among mechanical origin sensors and make the mechanical origin more accurate.

Note:

- When using the TIMING output, stop the motor output axis at an integral multiple of 7.2°.

5.7.2.2. CWLS / CCWLS / NORG / ORG Output

These are for outputting a CW limit sensor, CCW limit sensor, near origin sensor, and origin sensor installed at an automatic stage.

Note:

- The output logic of a sensor is different from stage to stage. Be sure to check the output logic of the automatic stage to be connected before setting an upper level controller.

5.7.3. Timing Chart

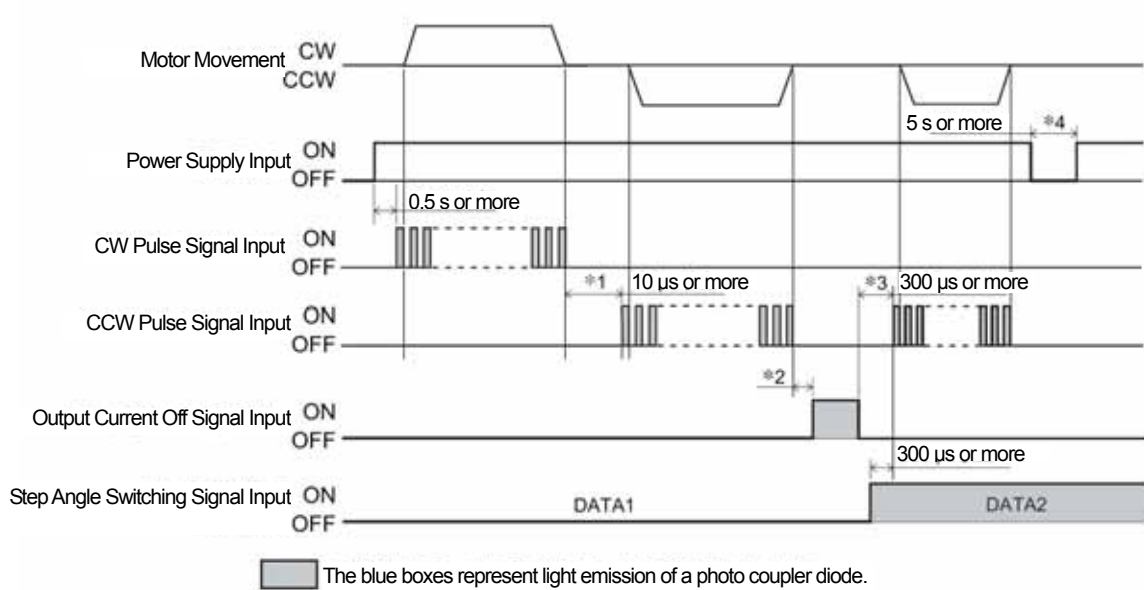

- *1: The time of 10 μs or more to switch from CW pulse to CCW pulse reflects the response time of circuit. Set the time of a motor responding.
- *2: This will vary depending on the load inertia moment, load torque, and/or self-starting frequency.
- *3: Do not input a pulse signal right after switching the output current off signal OFF because it will affect the starting performance of a motor.
- *4: Wait at least five seconds before restoring power.

6. Setting

DP112MS can set various items including step angles, a pulse input method, and a smooth drive function. The section describes how to set those items.

(DP112 does not have such setting functions.)

6.1. Opening / Closing of Chassis

(1) Remove the four screws at the side of DP112MS.

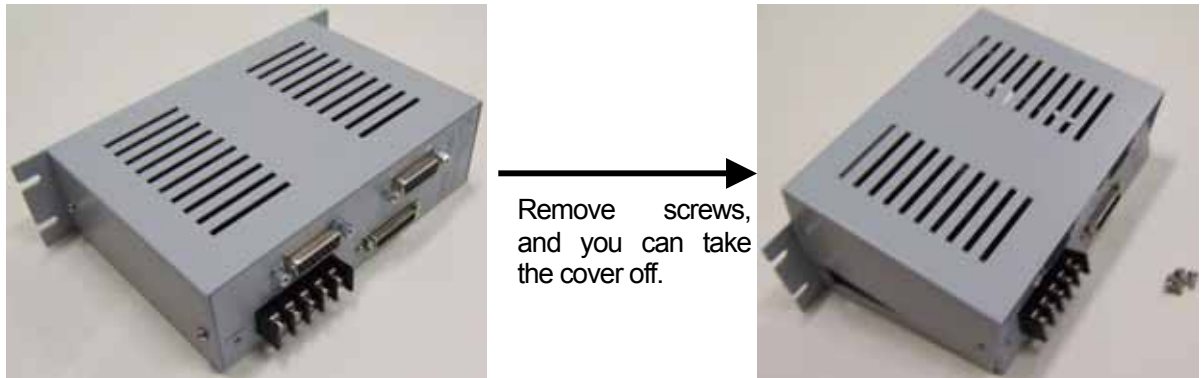

(2) The setting areas (encircled) will appear once taking the cover off as shown below. You can set the driver with the use of a tweezers, precision driver or other tools.

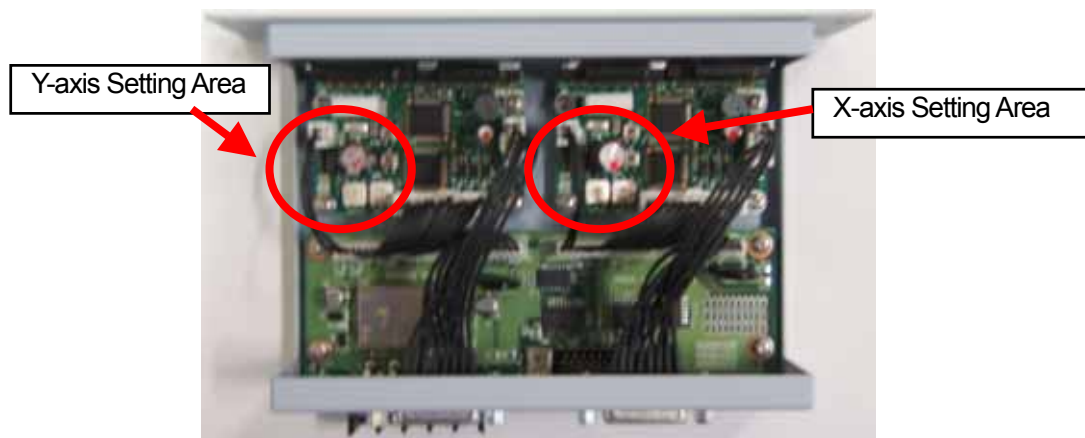

Note:

- Be sure to cut off the power supply before opening or closing the chassis. Otherwise, it may cause a fire, physical injury, or damages to the device.
- When setting the driver, be careful not to touch it with electrically charged hands. Electrostatic discharge may damage the product.

6.2. Setting of Step Angle

To set the step angle of a motor, use the step angle setting switches [DATA1] and [DATA2], and the resolution capability change-over switches [R1] and [R2].

Factory Default: R1

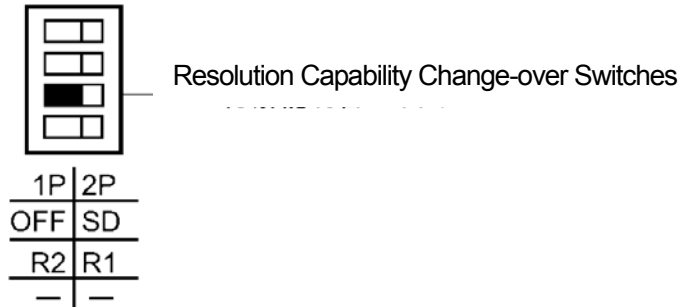

The two step angle setting switches [DATA1] and [DATA2] allow you to set 16 levels of step angles for each and operate the unit by selecting the switch with the C/S (step angle switching) input. For more details on how to operate the C/S input, please see 5.7.1.3 C/S (Step Angle Switching) Input.

To change the setting of step angles, switch the scales of DATA1 and DATA2 using a precision driver.

You can choose from 16 types of setting ([0] - [F]) for step angle 1 and step angle 2. The following table shows which scale corresponds to which step angle.

The step angle corresponding to each scale is the same for both DATA1 and DATA2.

Factory Default: [DATA1:0]

[DATA2:0]



The following table shows the case of basic step angle of 0.72° / STEP.
 The equation holds true: Step angle = Basic step angle / Division number.

R1			R2		
DATA1 DATA2	Division Number 1	Step Angle 1	DATA1 DATA2	Division Number 1	Step Angle 1
0	1/1	0.72°	0	X2.5	1.8°
1	1/2	0.36°	1	X1.25	0.9°
2	1/2.5	0.288°	2	1/1.6	0.45°
3	1/4	0.18°	3	1/2	0.36°
4	1/5	0.144°	4	1/3.2	0.225°
5	1/8	0.09°	5	1/4	0.18°
6	1/10	0.072°	6	1/6.4	0.1125°
7	1/20	0.036°	7	1/10	0.072°
8	1/25	0.0288°	8	1/12.8	0.05625°
9	1/40	0.018°	9	1/20	0.036°
A	1/50	0.0144°	A	1/25.6	0.028125°
B	1/80	0.009°	B	1/40	0.018°
C	1/100	0.0072°	C	1/50	0.0144°
D	1/125	0.00576°	D	1/51.2	0.0140625°
E	1/200	0.0036°	E	1/100	0.0072°
F	1/250	0.00288°	F	1/102.4	0.00703125°

Note:

- Step angles are a theoretical value.
- For a geared type, an actual step angle will be Step angle / Reduction ratio.
- The C/S (step angle switching) input will be enabled for the division number selected in step angle 1 or step angle 2 only.
- Do not change the C/S input and a step angle setting switch while a motor is running. A motor may lose steps and stop operating.

6.3. Pulse Input Method

You can choose a pulse input method between the 2 pulse input and 1 pulse input according to an upper level controller.

Factory Default: [2P: 2 pulse input method]

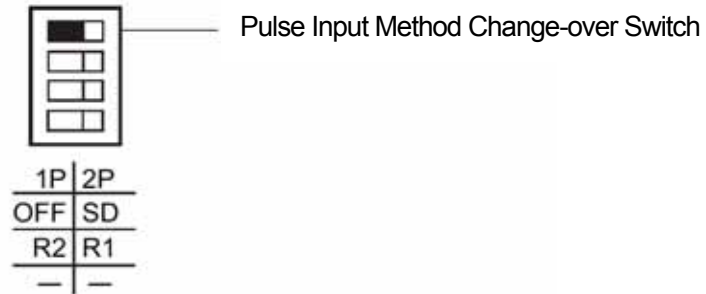

- When controlling a motor with the two pulse signal inputs of a CW and CCW pulse signals, set the pulse input method change-over switch to [2P].

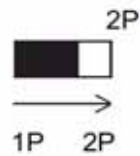

- When controlling a motor with a pulse signal and the signal that specifies the rotation direction of a motor, set the pulse input method change-over switch to [1P].

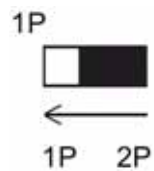

6.4. Smooth Drive Function

The function allows a motor to drive with low vibration and low noise like at low speed operation without changing the setting of step angle.

It will automatically divide step angle into 1/16 according to a pulse signal. It does not require changing a pulse signal at the upper level controller side (speed, the number of pulses).

The smooth drive function is effective only when the step angle is set in the range of [DATA:0] - [DATA:6] for [R1], and [DATA:0] - [DATA:7] for [R2].

(The values of [DATA] represent the setting value for the step angle setting switches for [DATA1] or [DATA2] as shown in 25 page.)

Factory Default: [SD: Smooth drive enabled]

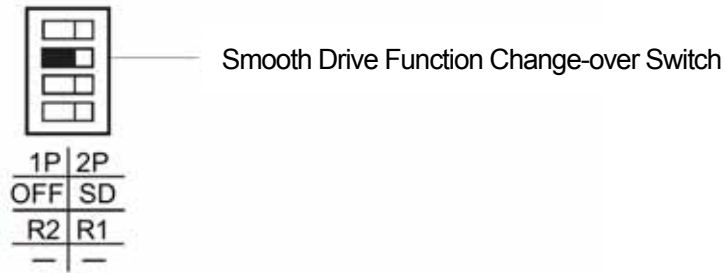

- When using the smooth drive function, set the switch to [SD].

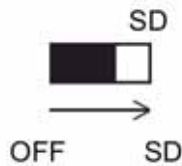

- When not using the smooth drive function, set the switch to [OFF].

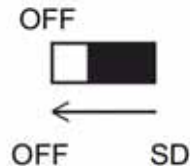

Note: When setting the step angles to the division larger than 10 (0.072°)*, the smooth drive function will not be enabled. Even if you set the switch to [SD], the setting will be ignored. (It will work in the same way as when you set the switch to [OFF].)

* For a high resolution capability type, 0.036°

7. Checkup

It is recommended to regularly inspect the product for the following items after using the product. If you find anything abnormal, stop using the product and contact our OST Division Customer Service.

Items to be checked:

- Is there any damage or stress applied to the cables connected? Are the connection parts loosened?
- Is dust accumulated in the ventilation port of the driver pack? Is the port clogged?
- Is there any odd smell or anything abnormal?

8. Failure Diagnosis and Actions to be Taken

When you drive an automatic stage, sometimes a motor or driver may not operate properly due to wrong speed setting or connection.

If you cannot operate an automatic stage correctly, take appropriate actions according to the section. If you still cannot solve a problem, please contact our OST Division Customer Service.

Phenomenon	Possible Cause	Actions to be Taken
A motor is not excited.	Poor connection in cables for automatic stage or power supply.	Check that cables for automatic stage or power supply are properly connected.
A motor easily spins by hand.	AWOFF (output current off) input is ON.	Turn the AWOFF (output current off) input OFF and check that a motor is excited.
A motor does not rotate.	Poor connection in a pulse input line.	<ul style="list-style-type: none"> • Make sure that an upper level controller and the driver pack are properly connected. • Check the specifications (voltage, range) for pulse input. • Check that the connection to ground for an upper level controller and the driver pack is properly established.
	Both CW and CCW inputs are made at the same time.	Input a pulse to either CW or CCW input. Be sure to turn OFF the terminal with no input.
	Emergency stop is activated.	<ul style="list-style-type: none"> • Check that the emergency stop button is not ON. • Review the specifications of the upper level controller for emergency stop.
A motor spins in the opposite direction to the specified one.	CW and CCW inputs are reversely connected.	Make sure to connect the CW pulse to Pin. 9 or 27 and the CCW pulse to Pin 10 or 28.
A motor operates in an unstable way.	Poor connection in a pulse input line.	<ul style="list-style-type: none"> • Make sure that an upper level controller and the driver pack are properly connected. • Check the specifications (voltage, range) for pulse input. • Check that the connection to ground for an upper level controller and the driver pack is properly established.
The displacement amount of a motor does not correspond to the setting amount.	Switching of C/S (step angle switching) input is not correct.	Check the status of the C/S (step angle switching) input.
	Too few or too many output number of pulses.	Check that the number of pulses needed to operate at the set step angles is output or not.
Current does not drop when a motor is at rest.	The CDINH (current reduction disabling) input is ON.	Turn the CDINH (current reduction disabling) input OFF.
	The CW and CCW inputs or pulse inputs are ON after a pulse stops.	Be sure to turn them OFF after a pulse stops.

Phenomenon	Possible Cause	Actions to be Taken
A motor loses steps while accelerating or running.	Too much load or too big load fluctuations.	Check that there are any large load fluctuations while a motor is running. If the problem does not appear when you adjust the operation speed of a motor to low speed (large torque), you need to review the load conditions.
	Too high starting pulse speed.	Reduce the starting pulse speed so that a motor can start stably.
	Too short accelerating (decelerating) time.	Extend the accelerating (decelerating) time so that a motor can start stably.
	Affected by noise.	Check the operation using only the driver pack, automatic stage and the upper level controller needed for operation. If you confirm the impact by noise, take appropriate measures including separating it from the noise source, reviewing the wiring, changing the signal cable to a shielded wire, and attaching a ferrite core.
A motor vibrates a lot.	The motor on an automatic stage is resonating.	If the vibration gets lower when you change the operation pulse speed, the motor is resonating. To reduce the vibration, you can change the setting of the operation pulse speed, or attach a clean dumper (sold separately).
A motor is too hot.	Too long operation time.	You can either shorten the operation time or extend the halt time. Be sure to use the product so that the temperature of a motor case will not go over 100 °C.
	The CDINH (current reduction disabling) input is ON.	Turn the CDINH (current reduction disabling) input OFF.
The TIMING output is not output.	You switched the C/S (step angle switching) input when the TIMING output is not output.	Be sure to turn the C/S (step angle switching) input ON only when the TIMING output is output.

9. Warranty and Service

9.1. Warranty

When you contact us, please let us know the serial number marked on your product.

We keep record of a delivery date by serial number.

The warranty term is 1 year after delivery.

Please note, however, the following cases will be exempted from warranty and repair work will be subject to fees:

- The failure or damage is attributed to wrong usage or unauthorized remodeling or repair conducted by someone who does not belong to our company
 - The failure or damage is attributed to improper handling such as a drop during transporting or moving the product
 - The failure or damage is caused by a fire, salt damage, gas damage, abnormal voltage and other natural disasters including earthquake, lightning, and wind and flood damage
 - The failure or damage arises from a failure to follow the instructions and cautions described in this manual
- * We do not take responsibility for any direct or indirect damage that may arise from a failure of the product or the use of it.

9.2. Service

Before requesting repair, please check the items described in 8. 8. Failure Diagnosis and Actions to be Taken.

If you still have questions, please contact our OST Division Customer Service.

<Within Warranty Period>

If the failure arises even though the product has been used correctly with all the cautions included in the instruction manual observed, we will repair the product for free.

For any other failure as described above as exempt from warranty, the repair will be subject to fees.

<After Warranty Period Expires>

If the product can maintain its function by repair, we will repair it upon request with charge.

9.3. Repair Period

The performance parts for service (parts needed to maintain the function) of the product will be stored for one year after the manufacturing of the part is terminated. Therefore, the period you can receive our repair service will be basically the same period. A repair job may sometimes be possible, however, even after the maintaining period of the part, so please contact our OST Division Customer Service.

- * As for a failure that occurs to the product, we will take no other responsibility than free of charge repair in accordance with the warranty.

<Contact Information>

SURUGA SEIKI CO.,LTD.

**a MISUMI Group Company
OST Division Customer Service**

TEL: 0120-789-446

FAX: 0120-789-449

<http://www.suruga-ost.com/>

E-mail e-ost@suruga-g.co.jp

Tokyo Sales Office

3/F Konan YK Bldg, 2-4-12, Konan, Minato-ku, Tokyo, 108-0075 Japan

TEL 03-6711-5014; FAX 03-6711-5021

Headquarters & Factory

505, Nanatsushinya, Shimizuku, Sizuoka-shi, Shizuoka, 424-8566

TEL 054-344-4615; FAX 054-346-1196